



IN-TANK TECHNOLOGY



PLEASE NOTE OUR NEW STREET ADDRESS
Custom Masters/Flo King Filter Systems
401 Lake Bennett Ct.
Longwood, FL 32750-6341 USA

FLO KING BXL5000 OPERATIONS MANUAL

www.floking.com



Pioneers of In-Tank Filtration ★ www.floking.com

CUSTOM MASTERS, INC. • 401 LAKE BENNETT CT., LONGWOOD, FL 32750-6341 USA • 407-331-4634 FAX 407-331-0575



BXL5000 OPERATIONS MANUAL

WELCOME TO THE FLO KING EXPERIENCE!

Congratulations on your purchase of the Flo King BXL5000 in-tank, sealless, centrifugal pump. This 4-in-1 unit can be used to pump, filter, agitate, and treat a wide variety of chemical- and metal-containing solutions. The BXL5000 has a maximum flow rate of 5000 gallons per hour (19,000 liters/hour).

Because of the unique design of the BXL5000 and our selection of high-quality reusable and disposable filter media, the life of process baths and associated pre- and post-treatment formulations can be extended while using fewer cartridges.

The excellent agitation and counterflow action produced by the BXL5000 also result in uniform solution temperature and chemical consistency, as well as continual recirculation to escort surface particulates down to the filter media for efficient removal.

The BXL5000 also eliminates leaks and spills that can present environmental and safety problems.

Flo King pumps and filter systems are built to last. To maximize the performance and life of your Flo King system, it is important that you read and understand the instructions in this manual.

BEFORE UNPACKING YOUR UNIT

Follow these instructions before unpacking your Flo King system:

1. Inspect contents before removing pump from shipping container to make certain that no damage has occurred during shipment.
2. Before removing pump from shipping container, plug pump cord into properly grounded ac outlet of the correct voltage for the unit you have ordered, and run pump to make sure damage has not occurred during shipping.
3. If unit seems to be damaged, notify carrier (UPS, etc.) at once, then notify CUSTOM MASTERS INC., manufacturer of the Flo King system, at 407-331-4634 (FAX 407-331-0575) for further instructions.



LIMITED ONE-YEAR AND 90-DAY GUARANTEE

The Flo King motor is guaranteed for 90 days against defects in material and workmanship.

All other Flo King filter system components are guaranteed for one year from date of purchase against defects in material and workmanship.

This guarantee does not cover damage caused by misuse or negligence. If the Flo King filter system fails to operate during the guarantee periods, notify CUSTOM MASTERS for repair or replacement without charge at the manufacturer's option. If unit must be replaced, the transportation costs for returning the defective pump are the responsibility of the consumer.

Dismantling the motor from the pump in any way may void this guarantee.

SAFETY PRECAUTIONS

All safety-related procedures must be followed to prevent injury or damage to personnel, the workplace, and the environment. These include the following:

1. Make sure only trained and qualified personnel install, use, and maintain Flo King equipment. Handling of any equipment by unauthorized personnel can be dangerous.
2. Always wear proper protective gear such as gloves, aprons, and goggles.
3. To avoid electrical shock, never handle this equipment when wet or standing in water.

When handling equipment for any reason, make sure power supply is disconnected.

4. Do not grab unit by motor. During normal operation, motor becomes "hot to the touch."
5. Use only the power supply cord furnished with the BXL5000. Do not alter the factory-furnished power supply cord. Plug the cord into a properly grounded outlet of the correct voltage for the unit you have ordered. Do not use an extension cord!
6. Keep power supply cord out of contact with hot, sharp, highly corrosive and other potentially damaging objects and solutions.

ELECTRICAL & ANTI-FIRE WARNINGS

1. Use only the power supply cord furnished with the BXL5000.
2. Do not alter the factory-furnished power supply cord.
3. Plug the factory-furnished cord into a properly grounded outlet of the correct voltage for the unit you have ordered.
4. Do not use an extension cord!
5. Keep factory-furnished power supply cord out of contact with hot, sharp, highly corrosive and other potentially damaging objects, materials, and solutions.

Failure to abide by these measures will void the Flo King warranty and relieve Custom Masters from any and all electrical and fire liability claims.

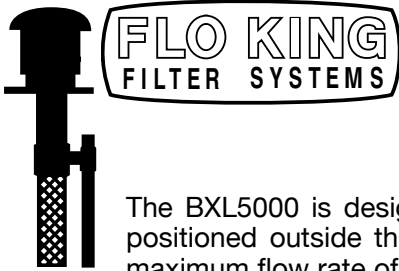

THE FLO KING BXL5000

The BXL5000 is designed for tanks where overhead clearance is limited. The motor is inverted and positioned outside the tank, taking up only 2" (5 cm) of space above the tank. The unit provides a maximum flow rate of 5000 gallons per hour. Use it stationary on one tank or move it from tank to tank. Multiple body lengths (8", 10", 12", and 14") enable use of the BXL5000 in tanks with varying solution levels and depths. The BXL5000 comes ready to operate and includes the items shown in the labeled photograph below. For best results in most metal-finishing solutions, use the BXL5000 with our PMCA Permacore Magnum reusable or FK50 Poly-Spun disposable filter cartridges in the appropriate length.

FLO KING BXL5000 SPECIFICATION

PUMP MATERIALS: Available in CPVC, polypropylene, PVDF (Kynar), and stainless steel (see Bulletin 23.5) as pump materials of construction. Standard shaft is made of Teflon-covered 303 stainless steel. A titanium-tip or Hastelloy-C276-tip shaft is available on special-order basis. Call for prices.

FLOW RATE: 5000 gallons per hour (19,000 liters per hour) at 60 Hz. A flow-rate reduction of about 18% (±3%) is typical when operating at 50 Hz.

PRESSURE: 27 feet (8.2 meters) of head pressure

WEIGHT: About 29 pounds (13 kg) in CPVC, depending on pump body length

MOTOR: Epoxy-coated, TEFC, Thermally Protected. Available in (specify voltage when ordering):

- Single phase, 3/4 HP (560 watt), 115/230 V, 9.6/4.8 A, 60 Hz, 3450 rpm.
- Single phase, 3/4 HP (560 watt), 110/220 V, 9.2/4.6 A, 50 Hz, 2850 rpm.
- Three phase, 1 HP (760 watt), 220/460 V, 3.0/1.5 A, 60 Hz, 3450 rpm. *Note: There is an additional charge for three-phase motors.*

RUNNING PUMP DRY DOES NOT DAMAGE MOTOR, PUMP, SEALS OR BEARINGS

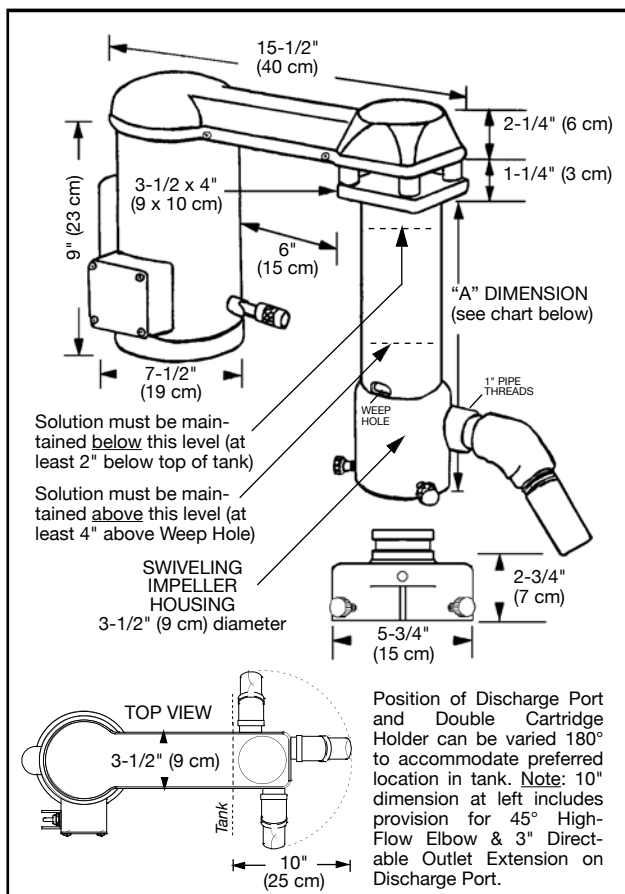
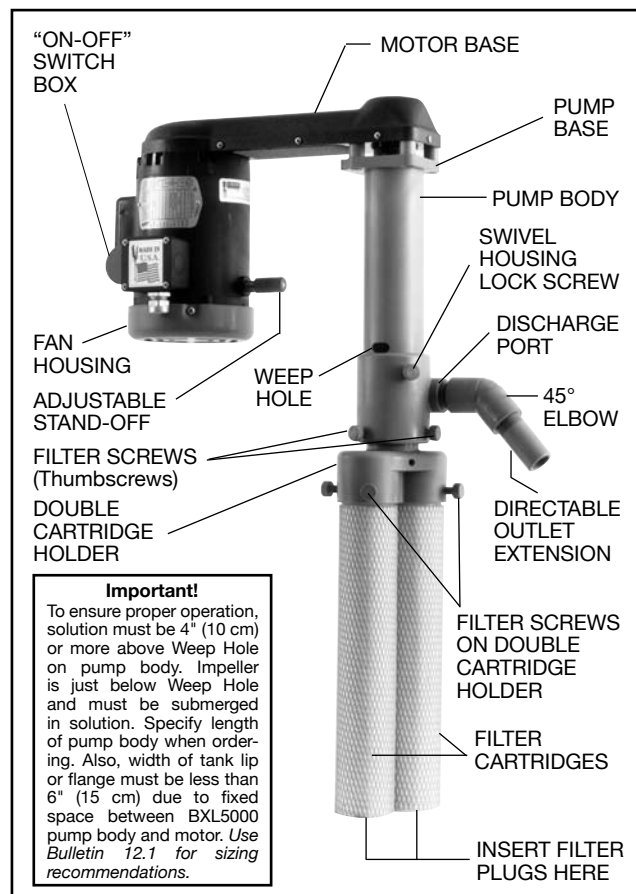

MEASUREMENT FROM BOTTOM OF PUMP BASE TO BOTTOM OF IMPELLER HOUSING ("A" DIMENSION)				
PUMP MODEL	BXL5000-8	BXL5000-10	BXL5000-12	BXL5000-14
"A" DIMENSION	10-3/4" (28 cm)	12-3/4" (32 cm)	14-3/4" (38 cm)	16-3/4" (43 cm)

IN-TANK TECHNOLOGY

The Original 4-in-1 FLO KING



FLO KING BXL5000 EXPLODED VIEW

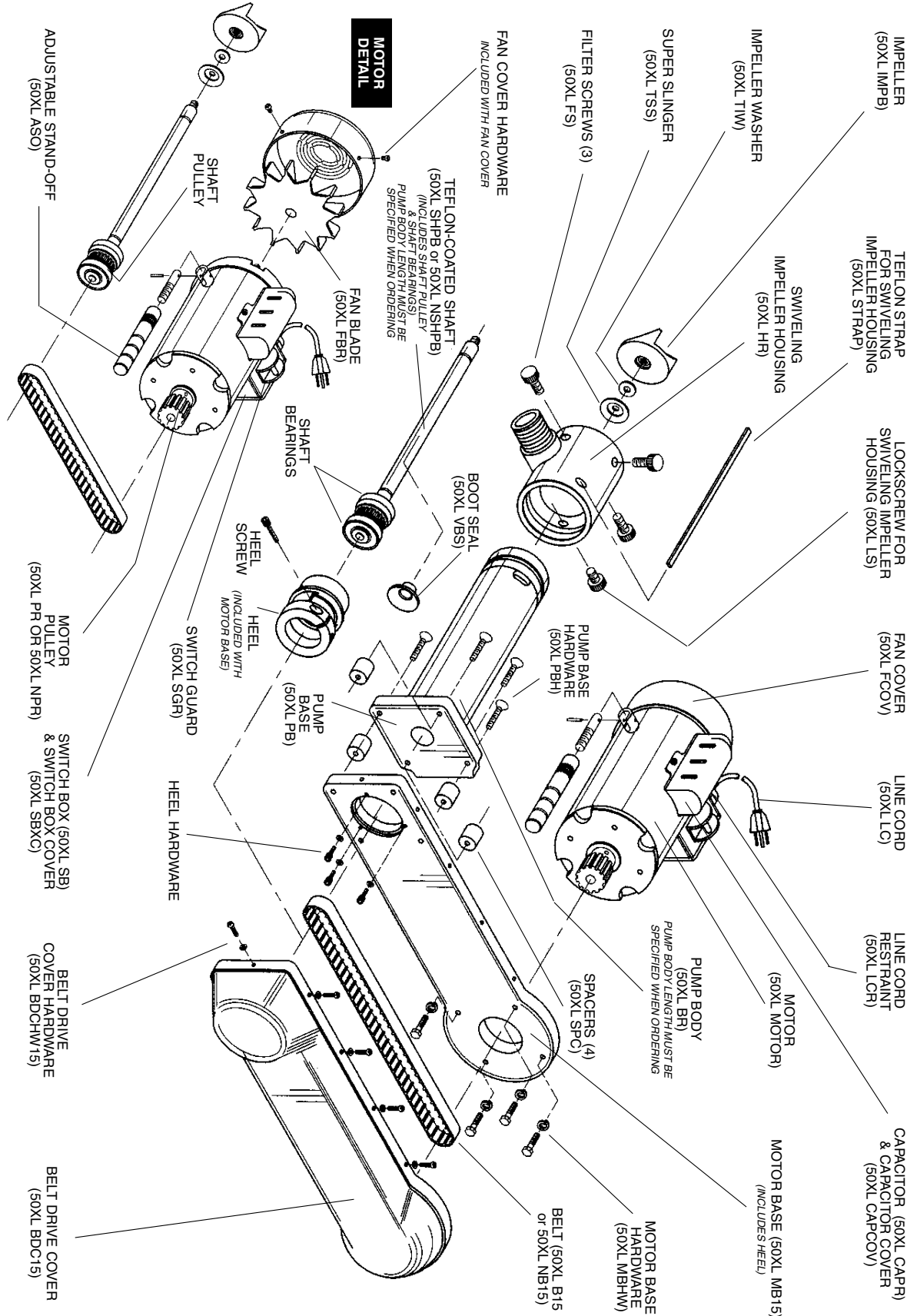

IMPELLER (50XL IMPB)
 TEFLON STRAP FOR SWIVELING IMPELLER HOUSING (50XL STRAP)
 LOCKSCREW FOR SWIVELING IMPELLER HOUSING (50XL LS)
 FAN COVER (50XL FCOV)
 LINE CORD (50XL LC)
 LINE CORD RESTRAINT (50XL LCR)
 CAPACITOR (50XL CAPR) & CAPACITOR COVER (50XL CAPCOV)

IMPELLER WASHER (50XL TWM)
 SWIVELING IMPELLER HOUSING (50XL HR)
 PUMP BASE HARDWARE (50XL PBH)
 MOTOR (50XL MOTOR)
 MOTOR BASE (50XL MB15) (INCLUDES HEEL)

SUPER SLINGER (50XL TSS)
 FILTER SCREWS (3) (50XL FS)
 MOTOR BASE HARDWARE (50XL MBHW)
 BELT (50XL B15 or 50XL NB15)

FAN COVER HARDWARE (INCLUDED WITH FAN COVER)
 TEFLON-COATED SHAFT (50XL SHPB or 50XL NSHPB) (INCLUDES SHAFT PULLEY & SHAFT BEARINGS) PUMP BODY LENGTH MUST BE SPECIFIED WHEN ORDERING
 BOOT SEAL (50XL VBS)
 SPACERS (4) (50XL SPC)

MOTOR DETAIL
 FAN BLADE (50XL FBR)
 SHAFT BEARINGS
 HEEL SCREW (INCLUDED WITH MOTOR BASE)
 HEEL (50XL HB)
 HEEL HARDWARE

SHAFT PULLEY
 PUMP BASE (50XL PB)
 SWITCH GUARD (50XL SGR)

ADJUSTABLE STAND-OFF (50XL ASO)
 MOTOR PULLEY (50XL PR OR 50XL NPR)
 SWITCH BOX (50XL SB) & SWITCH BOX COVER (50XL SBXC)

BELT DRIVE COVER HARDWARE (50XL BDC HW15)
 BELT DRIVE COVER (50XL BDC15)



BXL5000 INSTALLATION

The Flo King BXL5000 filter system is preassembled and ready to operate after removal from the box. Referring to Page 3 for parts identification, just follow these instructions:

1. Lift pump from box. Lay pump on side, on flat surface.
2. If you intend to use two filter cartridges on your BXL5000, insert Double Cartridge Holder into Swiveling Impeller Housing. Then tighten Filter Screws (thumbscrews) to hold Double Cartridge Holder in place. Do not over- or under-tighten Filter Screws. Do not use tools. Just tighten snugly by hand. (NOTE: Double Cartridge Holder is unnecessary if you intend to use only one filter cartridge on your BXL5000. In this case, insert single filter cartridge directly into Swiveling Impeller Housing, then tighten Filter Screws until snug.)
3. Insert filter cartridges into Double Cartridge Holder. Then tighten Filter Screws to hold filter cartridges in place. (CAUTION: Do not over- or under-tighten Filter Screws. Just tighten snug enough to hold filters in place.)
4. Insert Filter Plug(s) into hole(s) at bottom of filter cartridge(s).
5. Screw Elbow and Directable Outlet Extension onto Discharge Port and turn as necessary to achieve desired counterflow agitation pattern in tank. (Suggestion: Generally, it is advisable to slant Directable Outlet Extension at a slight angle toward tank wall rather than toward center of tank.) Counterflow agitation is important to continually skim solution surface and keep particles in suspension so they can be captured quickly by filter media and not settle on tank bottom. This is achieved as natural byproduct of filtration with Flo King system as filtered solution is expelled from pump Discharge Port.

You are now ready to install the system in the tank you wish to filter. Refer to labeled photos on Page 6.

6. Set pump into tank. Make sure Motor Base is resting on tank lip. Determine desired position of Elbow and Directable Outlet Extension (see Item #5 above). To position pump as desired, note that Swiveling Impeller Housing rotates 360° (see Page 7, “BXL5000 Swivel-Head Feature.”). Double Cartridge Holder also swivels for positioning purposes.

7. Referring to labeled photo and illustration on Page 3, make sure that “Weep Holes” on pump Body immediately above Discharge Port are submerged at least 4 inches (102 mm) below solution. This will ensure that the Impeller is spinning in solution. The Impeller must be submerged for the pump to function properly, to ensure self-priming operation, and to prevent aeration and/or foaming of solution. Also, make sure that solution is at least 2" below Pump Base to prevent solution splashing and fuming on Motor Base, bearings, and related components.

8. Use Adjustable Stand-Off to level Motor Base on tank lip. **CAUTION: Adjust until snug by hand-turning Stand-Off clockwise to tighten or counterclockwise to loosen. Do not overtighten! Overtightening of Adjustable Stand-Off and failure to provide ample space between pump Body and tank wall can result in warpage of pump Body, plus damage to Impeller and Shaft if they rub against pump Body!**

9. Make sure that Elbow, Directable Outlet Extension, and Filter Screws are not under pressure against tank wall

10. Make sure On-Off Switch is in off position. Plug electrical cord into properly grounded ac outlet of the correct voltage for the pump you have ordered. Pump will begin operating as soon as Switch is turned to on position.

11. If necessary, readjust Elbow and Directable Outlet Extension to modify counterflow agitation pattern in tank. Again, it is advisable to slant Directable Outlet Extension at a slight angle toward tank wall rather than toward center of tank. Double Cartridge Holder can also be adjusted after pump is mounted in tank.



**Low-Profile Unit, With Double Cartridge Holder,
Ready To Be Placed On Tank**

Motor Base
*(underneath
Belt Drive Cover)*

Pump Base

Adjustable Stand-Off
(in upright position)

Fan Cover

**Swiveling Impeller
Housing**

**Directable
Outlet
Extension**

Double Cartridge Holder

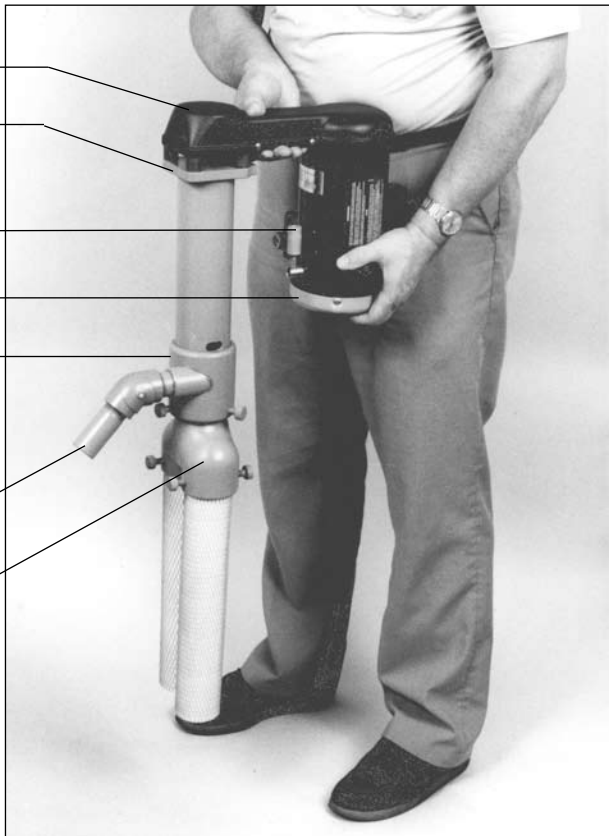

Correct Placement of Unit on Tank Lip

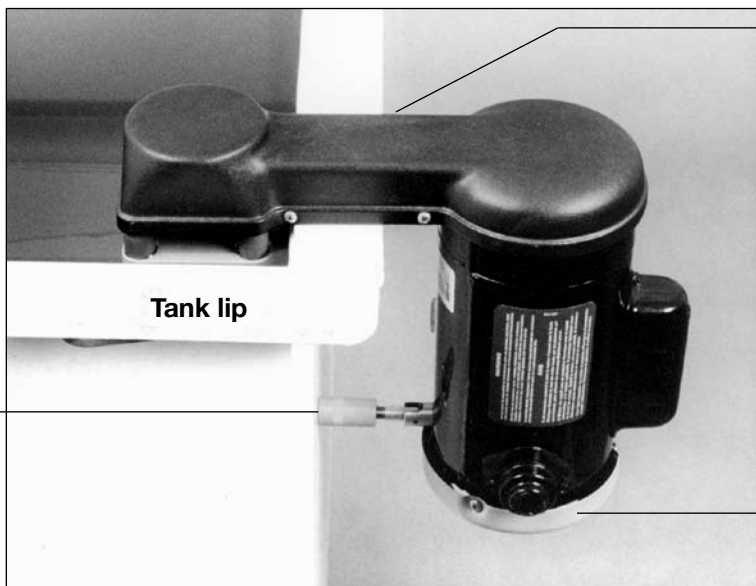

Motor Base
*(underneath
Belt Drive Cover)*

**Adjustable
Stand-Off**

Fan Cover

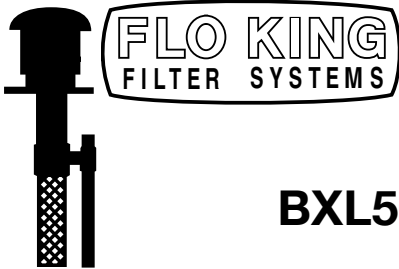

BXL5000 SWIVELING IMPELLER HOUSING

Swiveling Impeller Housing

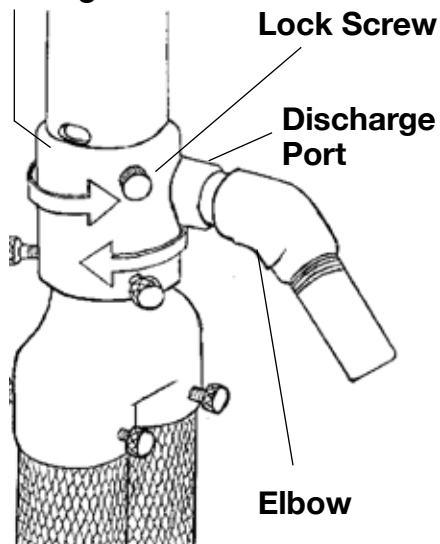

FOR INSTALLATION: ROTATING HOUSING

The Flo King BXL5000 has a unique Swiveling Impeller Housing that rotates 360°.

There are two primary reasons for using this swiveling feature: (1) to facilitate tank entry and placement of the BXL5000 and (2) to enable positioning of the Discharge Port and Elbow to achieve the best agitation pattern as solution is expelled from the filter system (*see Page 5 for explanation of importance of agitation pattern*).

When installing the BXL5000, visualize where you want the Elbow and Discharge Port to be positioned in the tank. Then just loosen the Lock Screw, rotate the Swiveling Impeller Housing to the desired position, and hand-tighten the Lock Screw snugly (*do not use tools or overtighten!*).

FOR REPAIRS: REMOVABLE STRAP FEATURE

The Swiveling Impeller Housing is attached to the pump Body by means of a removable Strap.

Unless the unit needs repair, there is no need to remove this Strap.

To Remove the Strap: Use awl or pointy probe to pry up end of Strap. Then grasp tip of Strap with needlenose pliers and pull Strap out. If Strap is hard to pull, rotate Swiveling Impeller Housing in opposite direction while pulling Strap with needlenose pliers.

Factory Repair Service: Flo King has a factory repair department, which customers are strongly encouraged to use. The repair department is provided as a service to our customers—and we therefore extend to you the lowest prices and fastest service possible.

Repairs Outside of the Factory: If it is not possible to return the disabled unit to the factory, refer to our website, www.floking.com, for repair instructions.

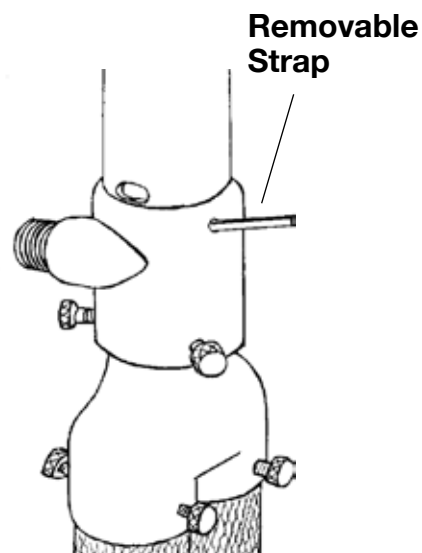



REMOVING BXL5000 FROM TANK AND CHANGING FILTER CARTRIDGES

Refer to Safety Precautions on Page 2.
Solution Safety Procedures Must Be Followed
To Prevent Injury or Damage to Personnel and Environment.

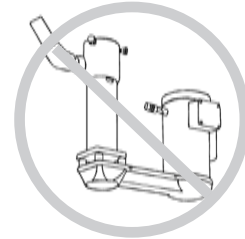

Warning!

Do Not Turn Flo King System Upside Down!

Do not turn Flo King system upside down when changing filters or any other time it has been exposed to corrosive solution! When pump is turned upside down, corrosive solution can drain onto Motor Base, Shaft bearings, and related components. Also, if laying pump on side to change filters, make sure solution does not drain onto these components.

To remove your Flo King BXL5000 from the tank, refer to labeled photos on Pages 3 and 6 and follow this procedure:

1. Turn On-Off Switch to off position. Unplug electrical cord for safety.
2. Put one hand firmly under Motor Fan Cover. (**CAUTION:** Motor can get hot during operation! Take necessary precautions.)
3. Release Adjustable Stand-Off by pulling Motor slightly away from tank and moving Stand-Off to upright position.
4. With hand still firmly under Fan Cover, grasp pump Body near junction of Pump Base.
5. Lift pump out of solution. Do so slowly to avoid dislodging sludge, particulates, and other debris captured by and adhering to filter media.
6. When removing pump from tank, it is advisable to set up a bucket or other receptacle near the tank. Let pump and filter drain into vessel to avoid dripping solution onto floor.
7. Loosen Filter Screws and allow spent filter cartridge(s) to drop into receptacle.
8. Attach new filter cartridge(s).

Optional Slide-In Filter Cartridge Adapter (SIFCA)

An option for removing filter cartridges is to use the Slide-In Filter Cartridge Adapter (SIFCA). This accessory enables the operator to change filter cartridges without moving the pump from the tank. *See Bulletin 19 in Flo King catalog for details.*

BXL5000 OPERATING INSTRUCTIONS

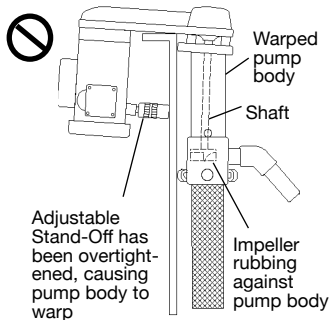

Adjustable Stand-Off Warning

DO NOT OVERTIGHTEN the Adjustable Stand-Off when leveling the Motor Base on the tank lip! As shown in the illustration at left, overtightening and failure to provide ample space between the pump Body and tank wall can result in warpage of the pump Body, plus damage to the Impeller and Shaft if they rub against the pump Body. Also make sure Elbow, Directable Outlet Extension, and Filter Screws are not under pressure against tank wall.

Operation & Shut-Down

Your Flo King BXL5000 was designed for continuous operation—24 hours a day. If, however, you prefer to run the unit only during certain hours, simply turn the On-Off Switch to the off position or discontinue the power supply.

Immersion and Corrosive Fume Warning

Never immerse the Flo King Motor in any solution. The totally enclosed, fan-cooled Motor is resistant to most chemical sprays and vapors, but not to immersion. Immersion in any solution may cause Motor failure and will void the Flo King guarantee.

Do not mount the Flo King pump in front of the ventilation exhaust. This will have the effect of exposing the Motor to a continuous draft of corrosive fumes that will shorten Motor life.

Impeller and General Pump Protection

To prevent foreign objects from getting trapped inside Swiveling Impeller Housing, never run pump without either a filter cartridge or a strainer accessory. When using a filter cartridge, *always* remember to install Filter Plug at bottom of filter cartridge. When using pump without filter cartridge, *always* attach Flo King strainer accessory to prevent pump from drawing foreign objects into Impeller.

Also, although rugged, Flo King pump should not be dropped or set down sharply on hard surface such as floor. This could cause damage to pump components, including Impeller. Make it a point to set unit down carefully.

ATTENTION: Electroless Nickel Users

It is advisable to strip the Flo King system periodically as electroless nickel deposits build up on pump parts such as Filter Screws and accessories. Also, the Flo King filter system aids in stripping electroless nickel deposits from tanks, heaters, racks, etc. When used with a Flo King FK50 or FK75 Poly-Spun filter cartridge, your stripping solution will last longer and your parts will be stripped faster and cleaner. The filter cartridge can be used many times before discarding.

Periodic Maintenance

Shut off power supply and use damp rag to wipe down exterior of Motor as needed to prevent residue buildup and promote cooler, more efficient operation. CAUTION: Motor may be hot.

Pioneers of In-Tank Filtration ★ www.floking.com

CUSTOM MASTERS, INC. • 401 LAKE BENNETT CT., LONGWOOD, FL 32750-6341 USA • 407-331-4634 FAX 407-331-0575

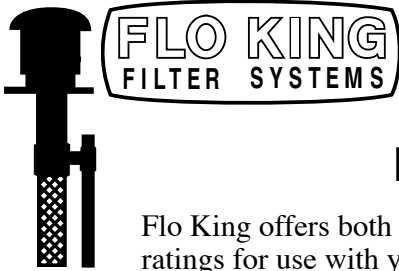

FLO KING FILTER CARTRIDGES

Flo King offers both disposable and reusable filter cartridges in a variety of lengths and micron ratings for use with your BXL5000.

Poly-Spun & Poly-Wound Disposable Filter Cartridges

Poly-Spun: This is our highest-quality and most popular disposable cartridge. It attaches directly to the Flo King pump and is especially recommended for the removal of fine to moderate particles. Our FK50 and FK20 cartridges provide outstanding filtration for most metal finishing solutions up to 200° F (93° C) while preserving the high flow rate and resulting agitation of the Flo King pump. Poly-Spun cartridges have a coreless, self-supporting structure and are made entirely of thermally bonded polypropylene fibers.

Poly-Wound: If disposable cartridges are preferred but are clogging too quickly, Poly-Wound is a candidate. This disposable cartridge is offered in 100, 200, and 400 microns for coarse filtration of solutions that generate considerable solids.

Purity Information: Because no resins, binders, lubricants or anti-static agents are used in manufacturing, no pre-wash is required for the Poly-Spun and Poly-Wound disposable cartridges.

Mounting to Pump: These disposable cartridges can be mounted directly to the Flo King pump or multiple cartridge holder. Alternatively, a Nut-Style Filter Holder is available—see PL26.21 in catalog

Disposal must be carried out in compliance with all federal, state and local regulations.

Magnum & Super Magnum Reusable Filter Cartridges

This blanket-like reusable filter material minimizes the costs and complexities associated with filter cartridge consumption and disposal because it can be reused many times.

The Magnum cartridges are available in three micron ratings. The MCA material (10 micron) is the most commonly used grade and is for general-purpose filtration; the MCB material (5 micron) is for finer filtration; the MCC material (1 micron) is for extra-fine filtration. The Magnum blanket is made of thermally bonded polypropylene fibers and is rolled around a polypropylene cartridge core and held in place with a polypropylene web.

The reusable Super Magnum blankets are made of a high-solids-holding, non-polypropylene material (polyester) and are available in two micron ratings—XC (75 micron, coarse) and XF (30 micron, finer). The Super Magnum material is the only type recommended for hard chromium plating solutions and other chromic-acid-containing baths at high temperatures. It is also often used for iron phosphate and other baths with appreciable solids. Super Magnum is not suitable for high-temperature alkaline cleaners and other aggressive caustic solutions.

Purity Information: The reusable filter blankets may contain a surfactant or mineral oil at less than 1 percent. Immersion in boiling deionized water may be desirable for sensitive applications.

Permacore vs. Standard Core

Two types of cores are available for the Magnum and Super Magnum reusable filters. One is a standard cartridge core. The second type, the Permacore, features at one end a hard, round piece of polypropylene, which fits snugly into the Flo King pump. The BXL5000 filter screws are tightened directly onto the Permacore head, thus alleviating wear and tear on the filter blanket. Either the standard or Permacore filters can be used with the BXL5000.

Poly-Spun & Poly-Wound Note: The Permacore is neither available for nor necessary with disposable filter cartridges.

(Also see Nut-Style Filter Holder—PL26.21 in catalog.)

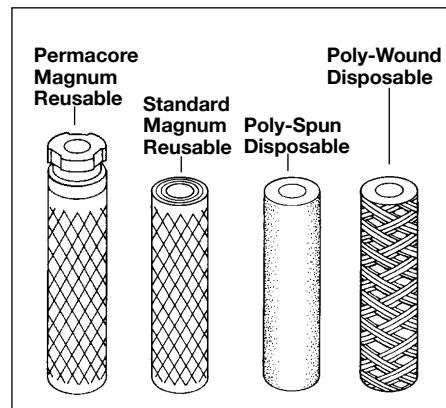



“MAGNUM” REUSABLE FILTER CLEANING & ASSEMBLY INSTRUCTIONS

Refer to Safety Precautions on Page 2. Solution Safety Procedures Must Be Followed To Prevent Injury or Damage to Personnel and Environment.

1. Remove Magnum filter cartridge from pump housing. Let drain and/or place in container.
2. Remove outside plastic Web. Stand cartridge assembly on flat surface in upright position. Grasp with both hands and slide web down about 2 or 3 inches (5 or 10 cm). Hold on to exposed filter blanket with one hand and pull web off Magnum assembly with twisting motion. (NOTE: If web is “locked on” with sludge, it may be necessary to spray outside of Magnum with water to “unlock” web.)
3. Unroll filter blanket from filter core. Most users then lay blanket on piece of grating over suitable tank, drum, reservoir or wastewater treatment pit and spray each side using an ordinary hose and spray nozzle (or, if available, pressure spray washer). Normally, this is sufficient for cleaning; however, some contaminants may build up and not flush out completely. In many applications, these contaminants can be removed easily by placing Magnum blanket in an appropriate chemical solution.

CAUTION: Never mix cyanide-laden materials with acids; this combination produces hydrogen cyanide gas, which is lethal if inhaled! The process solution to which the Magnum has been exposed must be compatible with the acid from a SAFETY and USE standpoint.

4. To wrap Magnum blanket around filter Core, lay blanket on flat surface. Blanket can be rolled while wet. Place core on blanket, making sure that top of blanket is even with core, and roll as tight as possible. (Note: If using PERMACORE filter element, allow PERMACORE head to lay off edge of flat surface while rolling blanket.)
5. Rest Magnum assembly in one plastic loading slat and place other loading slat on opposite side of Magnum filter to form a tube. Make sure plastic loading slats extend 2 inches (5 cm) beyond one end of Magnum.
6. Grasp Magnum about 4 inches (10 cm) from extended end. Slip plastic web over loading slats and pull down to end of assembly. Remove loading slats. Magnum is now ready to be used again.



Clean blanket.



Re-roll blanket around core.



(L-r) Place plastic loading slats over filter. Then slide web over slats and pull down. Remove slats and cartridge is ready to reuse.



PREMATURE FILTER CLOGGING

Filter Changes When Starting Up Your Flo King System

When you install your Flo King in a previously unfiltered or poorly filtered bath, you may find that dirt, sludge, and other solids emerge from the bottom of the tank.

Consequently, until removed, these built-up solids may cause your Flo King filter cartridges to clog up quickly.

Do not be alarmed!

This is exactly what your Flo King system was designed to do. The counterflow action and quick-capture features result in efficient filtration by suspending and then capturing the solids.

A few simple changes of the reusable Magnum filter will normally put your bath in good condition. (See "Cleaning & Assembly Instructions for Flo King Magnum Filter Cartridges" on Page 12.)

However, if your bath has a considerable solids build-up and you wish to avoid filter clogging and get a fresh start on your filtration program, we suggest you follow the "DE-SLUDGE Procedure" outlined on Page 14.



DE-SLUDGE PROCEDURE

For Cleaning & Purifying Dirty, Contaminated Solutions

These instructions for cleaning and purifying dirty and contaminated solutions are recommended for most plating and associated process solutions in the finishing industry. These instructions are a guide, however, and depend on qualified personnel for proper cleaning and operation of filter media and carbon purification methods.

Solids Removal

1. De-Sludge: Let solution settle for 24 hours or until sediment has dropped to bottom of tank.
2. De-Cant: Remove solution from tank very carefully, without disturbing sediment on bottom of tank. Remove sludge, clean tank, and pump solution back into tank. (See Flo King Catalog Bulletin 32, "Special Applications")
3. Filter: Place one or two Flo King filter systems on side of tank with directable outlet extension slanted slightly toward tank wall. This will start a counterflow agitation motion, which directs dirt and particles into filter media for solids removal.

Using Flo King Magnum or Super Magnum reusable filter cartridges or FK50 Poly-Spun disposable cartridges (see Catalog Bulletins 24 and 26), continue filtering until filter cartridges clog. This is determined visually by observing the solution; when there is little or no solution movement, the filter cartridges have clogged. Change or clean filter cartridges and continue filtering until filter cartridges are able to run several hours without plugging up. Ten turnovers generally produces a bath that filters particles in the range of 10 to 15 microns; 20 turnovers typically results in a 1- to 5-micron bath.

Carbon Purification

If solution is still cloudy after following the above procedure or if tests show the presence of organic contamination, carbon purification may be necessary. (Refer to Flo King Catalog Bulletin 28 for system size and method of carbon purification needed.)

1. Place carbon system in tank and run for several hours or overnight.
2. Test solution for organic contamination and continue until results are satisfactory.



FLO KING BXL5000 TROUBLESHOOTING

1. Symptom: Little or No Agitation or Solution Circulation.

Possible Problems: (a) Solution level is not sufficiently above “Weep Holes” immediately above Discharge Port on pump Body. In general, solution should be at least 4 inches (102 mm) above these Weep Holes (*but also at least 2" below Pump Base*). This will ensure that the Impeller is spinning in solution. (b) Filter cartridges have air in them. Soak cartridges for a few minutes in solution to be filtered. (c) Filter is clogged. Refer to “Premature Filter Clogging” and “De-Sludge” sections (Pages 12 and 13, respectively). (d) If problem persists, wrong filter media may be in use. Refer to Flo King Bulletins 24 and 26 in catalog and/or request our informational flyer “Guidance on Selecting Flo King Filter Cartridges.” Note: Filter cartridges that are too fine for the application can “choke” intake of pump, thus substantially reducing flow rate and agitation. (e) A foreign object has lodged inside Swiveling Impeller Housing (also look for buildup of chemical residues). Turn pump off and remove from solution as outlined on Page 8, “Removing BXL5000 from Tank...”. Remove foreign object or residue from Impeller area, then re-install pump according to “BXL5000 Installation” instructions on Page 5. (f) Belt on Motor is displaced or broken. In this case, there is *no* solution agitation or circulation because neither Shaft nor Impeller will turn. Contact Flo King factory or area distributor.

Important: To prevent foreign objects from getting trapped inside Swiveling Impeller Housing, never run pump without either a filter cartridge or a strainer accessory. When using a filter cartridge, *always* remember to install Filter Plugs at bottom of filter cartridges. When using pump without filter cartridge, *always* attach **Flo King** strainer accessory to prevent pump from drawing foreign objects into Impeller.

2. Symptom: Excessive pump vibration.

Possible Problem: Pump Shaft is out of alignment—normally due to excessively rough handling during shipping or use. If this occurs when unit is just received, immediately call the Flo King factory and shipper to report damage (see “Before Unpacking Your Unit,” Page 1). In any case, Shaft realignment should be done at Flo King factory.

3. Symptom: Excessive solution aeration or foaming.

Possible Problems: (a) Solution level is not sufficiently covering “Weep Holes” immediately above Discharge Port on pump Body. In general, solution should be at least 4 inches (102 mm) above these Weep Holes (*but also at least 2" below Pump Base*). (b) Filter cartridge is clogged. (Refer to “Premature Filter Clogging” and “De-Sludge” sections on Pages 12 and 13, respectively, as well as Flo King Bulletins 24 and 26 in catalog.) (c) Micron rating of filter cartridge is too fine for the application. Try a coarser filter cartridge (higher micron rating).

4. Symptom: Motor appears to be running hot.

Comment: Under normal operation, Motor runs “hot to the touch.” This should not be considered a problem. If Motor does run too hot, a built-in thermal protector will automatically shut it off. If this occurs, contact the Flo King factory or the area distributor. **Suggestion:** Closely observe unit in operation for first week or so to familiarize yourself with operating characteristics.

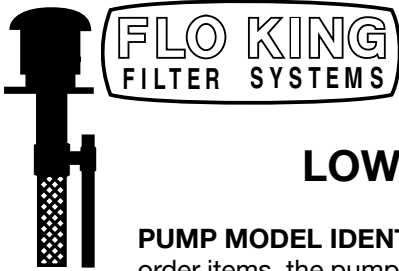

For additional repair information, visit our website at www.floking.com

LOW-PROFILE BXL5000 REPAIR INFORMATION

PUMP MODEL IDENTIFICATION: Before ordering parts, you must determine the pump model and, for many order items, the pump body length (see “Determining Pump Body Length” below). The model and body length may not appear on the pump body or motor. To identify the pump model, either: (1) check your original Flo King invoice; (2) write down the serial number, which appears on a silver sticker on the motor, then contact the Flo King factory for identification; (3) look for the horsepower rating on the motor: Unless the unit has been made for a special application, a 1/70th-hp motor is used on the Lab Series model; 1/15th hp on the BX650; 1/12th hp on the BX1200; 1/3 hp on the BXL2500 and BX3000; and 3/4 hp on the BX5000 and BXL5000; (4) compare your pump appearance and specs with the photos and specs shown for each model in our catalog or on our website (www.floking.com); or (5) contact the Flo King factory for further assistance.

DETERMINING PUMP BODY LENGTH: Flo King pumps are manufactured with different body and shaft lengths to satisfy the solution level from the top of the tank (freeboard) and, in many cases, the depth of the tank. You must therefore determine the length of your pump body before ordering certain parts. To determine the pump body length of the BXL5000, measure the “A” Dimension shown in the illustration at right. Then refer to the table below to find the corresponding pump model, such as BXL5000-10.

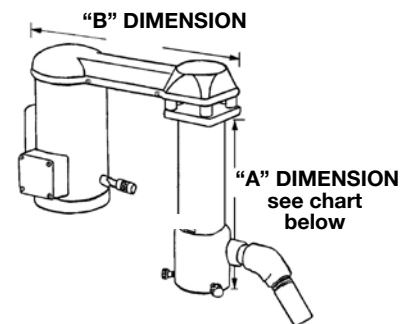

MEASUREMENT FROM BOTTOM OF PUMP BASE TO BOTTOM OF IMPELLER HOUSING (“A” DIMENSION)				
PUMP MODEL	BXL5000-8	BXL5000-10	BXL5000-12	BXL5000-14
“A” DIMENSION	10-3/4" (28 cm)	12-3/4" (32 cm)	14-3/4" (38 cm)	16-3/4" (43 cm)

PUMP MATERIAL OF CONSTRUCTION: It is essential that you identify the pump material of construction before ordering parts. Most Flo King units are made from CPVC or polypropylene. If the pump body is gray in color, the unit is made of CPVC plastic; if white, polypropylene. Kynar (PVDF) plastic and stainless steel are also sometimes used. If you are uncertain, check your original invoice or contact the Flo King factory for further assistance.

RECONDITIONED MOTORS: A reconditioned motor cannot be purchased unless you exchange a motor that is capable of being reconditioned. Motors with excessive corrosion, unacceptable ohm readings or those that have been immersed in solution cannot be reconditioned. In these cases, you must purchase a new motor.

PARTS AND SERVICE PRICES: The prices shown in our catalog under “Factory Service & Parts” include both parts and installation by our factory. In most cases, prices are the same for parts alone.

SERVICE: Due to the complexity of the BXL5000, special tools and techniques are required for repairs. We therefore strongly encourage you to use our factory repair service. Our Repair Department is staffed by trained technicians and provided strictly as a service to Flo King users. You will receive warranty coverage on all repairs we make. Use of independent motor repair shops is strongly discouraged! In our experience, they will always be more expensive because (1) Flo King factory repair prices already include labor and (2) their unfamiliarity with the design of our products can cause more damage and higher repair costs. For these reasons, we do not give technical assistance, drawings or parts information to independent motor repair shops.

RETURN PROCEDURE: Clean equipment in accordance with shipping regulations and send to **REPAIR DEPT., FLO KING/CUSTOM MASTERS, 401 LAKE BENNETT CT., LONGWOOD, FL 32750-6341 USA.** Make sure to include your name, address, and phone number so that the repair technician can contact you with an evaluation and estimate. A Return Authorization Number is not required. Use of the original Flo King box and packing will result in secure transport of your equipment and avoidance of factory charges for a new container.

ADDITIONAL REPAIR INFORMATION: Visit our website at www.floking.com