



COMPATIBLE WITH VIRTUALLY ANY CHEMISTRY

Compatible with virtually any chemistry. Excellent chemical resistance to aggressive acids! 9 element. Low watt density. Built-in thermal protector and grounded element. Fluoropolymer (PTFE) sleeved 304 stainless elements inert to most solutions. Corrosion-resistant head. 3000-18000 watts, 120-480 volts.



FEATURES

Inert to most aqueous acid, alkaline, anodizing, & pickling solutions.

Rugged, heavy wall PTFE covered stainless steel element reduces permeation. Guaranteed 100% pinhole free.

Space saving & long service life with low Watt density design of 10 W/in² (1.5 W/cm²)

Vapor-resistant, flame retardant polypropylene terminal enclosure with 3 ft (.9m) flexible PVC liquid tight conduit.

Lower watt densities for highly viscous solutions & technical acids.

9HX SERIES, NINE ELEMENT FLUOROPOLYMER (PTFE) HEATERS					
WATTS	VOLTS	HOT ZONE in/(mm)	OVERALL LENGTH in/(mm)	MODEL NUMBER	SHIP WGT. lbs/(kg)
3000	240	9	17	9HX3217-**	28
	480	(229)	(432)	9HX3417-**	(12.7)
4500	240	15	23	9HX4.5223-**	33
	480	(381)	(584)	9HX4.5423-**	(15)
6000	240	21	29	9HX6229-**	36
	480	(553)	(737)	9HX6429-**	(16.3)
9000	240	28	35	9HX9235-**	40
	480	(711)	(889)	9HX9435-**	(18.1)
12000	240	38	47	9HX12247-**	49
	480	(965)	(1194)	9HX12447-**	(22.2)
15000	240	47	59	9HX15259-**	60
	480	(1194)	(1499)	9HX15459-**	(27.2)
18000	240	55	68	9HX18268-**	67
	480	(1397)	(1727)	9HX18468-**	(30.4)

Three-phase standard. Single phase available. Add "-1" before thermal protector designator.

9HX Metal Heater

SPECIFICATIONS

Wattages	3,000 Watts to 18,000 Watts
Voltages	120 Volts to 480 Volts
Safety Features	Grounded internal metal element. Thermal protector built in. Replaceable PI protector standard for solutions . Non-floating construction. Other options available.

DIMENSIONS

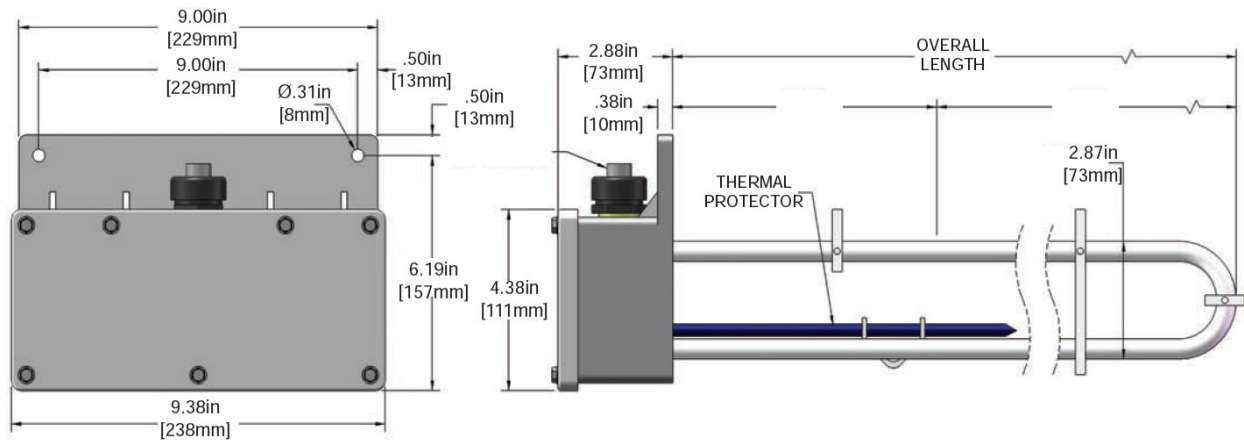

MODEL NUMBER BREAKDOWN

Series	Wattage	Voltage	Overall Length	Phase	Type of Protector	Wire & Conduit Length
9HX = PTFE	3 = 3000	1 = 120	17 = 3kW	No Designator = 3-phase (std.)	Replaceable Fuse	36" length standard (no designator)
	4.5 = 4500	2 = 240	23 = 4.5kW	1 = Single phase	P1 (std) = solutions up to 190°F	Specify variations from standard Ex: -X84 = 84"
	6 = 6000	3 = 380	29 = 6kW		Resettable Fuse	
	9 = 9000	4 = 480	35 = 9kW		P2 = solutions up to 190°F	
	12 = 12000	5 = 415	47 = 12kW		P8 = solutions up to 210°F	
	15 = 15000	6 = 600	59 = 15kW		P3 = solutions up to 250°F	
	18 = 18000	7 = 400	68 = 18kW			
		8 = 208				
		9 = 220				
		0 = 200				